

grazia&co melbourne
1 / 10-14 advantage road
highett, vic, 3190
phone +61 3 9555 5760

grazia&co sydney
12b, 32 ralph street
alexandria, nsw, 2015
phone +61 2 8914 0350

diiva floor fixed swivel stool



made in australia, the diiva floor fixed swivel stool features a fully upholstered seat and backrest. it has a powder coated metal column, cylinder shaped base cover and a concealed floor plate with pre drilled holes for fixing. optional brass or stainless footrail, the stool is available in a range of powdercoat colours and upholsteries. is available without a back.

this stool should be installed by a registered builder. a full installation guide for timber, concrete or tiled floors is available with purchase

grazia&co®

plain and perforated vinyl



zone vinyl - leather look origin: usa



textured vinyl - linen look origin: europe



koolio vinyl - finely textured, satin look origin: canada

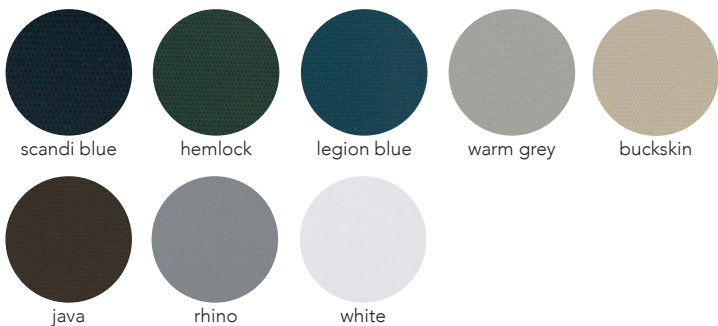

house leather corrected grain leather origin: europe



sheepskin origin: australia



house powder coat

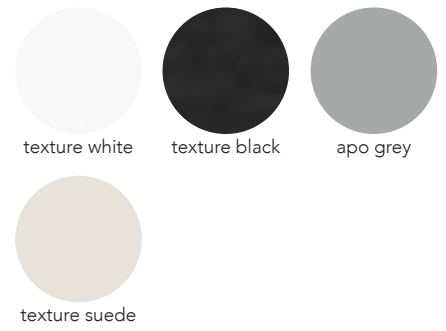

premium powder coat



footrail



custom

custom finishes as specified



1 - no back stool, no footrail

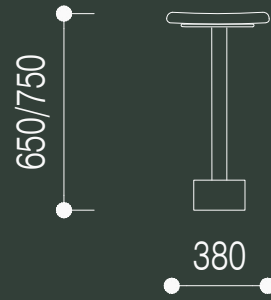
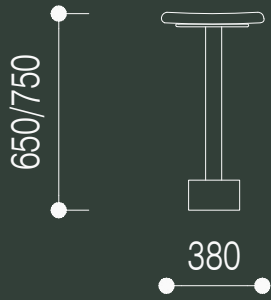

2 - no back stool with footrail

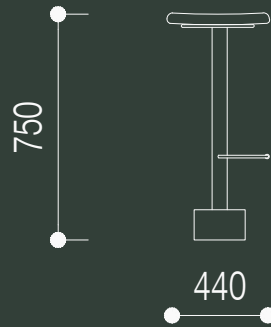
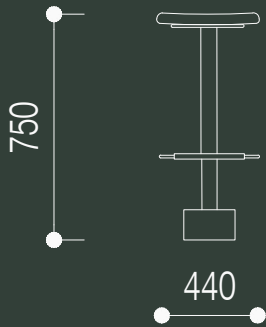

3 - with back stool, no footrail

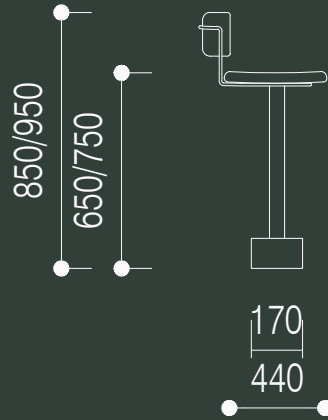
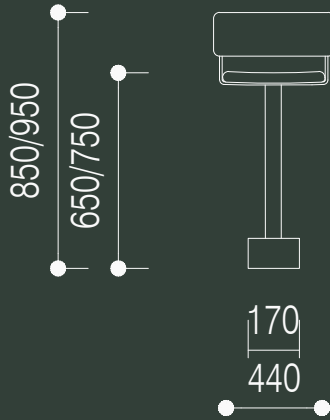

4 - with back stool with footrail

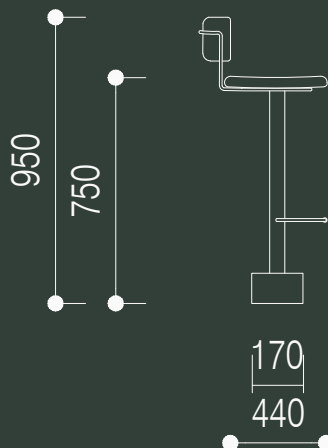
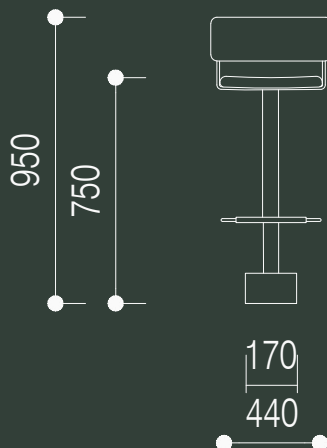

design registration no
202212897

year released
2022

warranty

- i. warranty period of 3 years for the structural integrity of the furniture under 'normal use'
- ii. the swivel mechanism is covered for 1 year under 'normal use'
- iii. warranty does not cover issues associated with the floor fixing installation (works done by others)
- iv. chipping and scratches on powder coated metal due to wear and tear are not warranted
- v. metal pieces that are not specific to outdoor use that are exposed to the elements are not warranted
- vi. raw metals oxidise and tarnish over time and not considered faults of manufacture.
- vii. fabric and leather wear and tear are not warranted.
- viii. fabric and leather that has faded or broken down due to exposure to sunlight or extreme weather conditions is not warranted.
- ix. care instructions and warranty claims of fabric to be addressed with the textile supplier or specifier.
- x. it is the responsibility of the specifier and/or supplier that has selected and/or supplied a fabric or leather through 3rd party suppliers to ensure it is free of faults and fit for purpose and application.

all terms outlined in this document are applicable exclusively to projects and orders that are based in australia. for warranty claims outside australia, please note that a 12 month warranty period will apply, all claims are to be taken up with the international selling agent. to view the full warranty please visit the [grazia&co website](#).

craftmanship:

designed and manufactured in australia

materials:

seat & backrest: ply seat and backrest with foam and specified upholstery.

frame: powder coated metal with brass or stainless steel footrail

lead time:

8-10 weeks. lead times may vary during peak periods

suitability:

indoor use



house leather

protect from direct sunlight, heat and weather. dust with a clean dry cloth or use the soft brush attachment on your vacuum cleaner. remove all liquid and food spills immediately. wipe with a clean cloth dampened with proprietary brand leather cleaner suitable for a surface finish leather.

house vinyl

maintaining and care of the upholstery should be done by regular vacuuming to remove dust and dirt. spot cleaning should be done immediately after a spill. first spot clean with mild soap and water. using a sponge to remove the stains, rinse with clean water. suntan lotions and sprays such as insect repellants may discolour the fabric. acid based liquids such as coffee, wine and fruit juice need to be wiped off immediately. the longer a stain or spill remains on the fabric the more difficult it can be to remove. do not use abrasive alcohol based or solvent based cleaners.

sheepskin

store away from direct sunlight and high heat sources, such as blow dryers and radiators. never rub or brush sheepskin when it's wet. to clean up small spills on your sheepskin upholstery, wipe with a damp cloth, and gently pluck any debris from the suede with tweezers. never use hot water. this causes permanent damage by stripping the natural oil, (lanolin) from the pelt making it very hard and rough. for professional cleaning, select a cleaner that specialises in leather/suede/fur.

custom specified upholstery

please refer to individual suppliers for information on care and maintenance of fabrics that have been specified by a designer, as these will be outside the standard grazia&co range. most interior upholstery fabric should be regularly vacuumed and kept away from direct sunlight.

powder coat

wash as required with warm soapy water using a soft clean cloth. for marine or commercial environments, we recommend regular cleaning. do not pressure wash or steam items that are powder coated. if powder coating chips due to a knock and / or rough treatment this is not covered by warranty. touch up paint can be purchased on request (depending on availability). scratches and chips should be repaired as soon as they appear.

to view the full care and maintenance please visit the [grazia&co website](#).

